



Oil burners fuel unit with pressure regulating Type S

www.deltapumps.com



S3



Oil burners fuel unit with pressure regulating

Type S

The DELTA fuel unit is an efficient modern oil burner pump with compact design and since its mounting flange, hub and shaft sizes are manufactured to international standards (EN 225), it can be fitted to every oil burner.

Features

- High suction power.
- Suitable for a one or two pipe systems.
- Bilateral delivery ports.
- Bilateral suction ports.
- Self priming.
- Balanced pressure regulator/cut-off valve giving constant pressure and effective cut-off (two pipe).
- Special shaft seal.
- Silent operation.
- Low power absorption.
- Easily fitted and adjustment.
- Provided with pressure gauge port.

Applications

The DELTA fuel unit type S is designed for pumping oil in high pressure oil burners. It is suitable for high capacity and high viscosity oil.

WARNING

It must not be used to pump water or acid.

Operation

The S fuel unit consists of a pump, filter and pressure regulator/cut-off valve housed within one casting. The pumping action is obtained from two spur gears (2) which are in mesh; one of which is connected to the driving shaft (3). The pump casting is drilled to provide the various oil ways, and therefore carries the suction (6, 7), return (5) and nozzle ports (9, 10). Pressure gauge port is also provided (8). Vacuum can be measured in the not used inlet port.

The S unit is available in two pipe and one pipe version. Both versions are self priming. On starting, the rotating gears expel the air from the suction chamber, through a vent groove in the piston to the return line in two pipe version, and through the nozzle line in one pipe version. On initial commissioning, it is possible to bleed the air more quickly, through the pressure gauge.

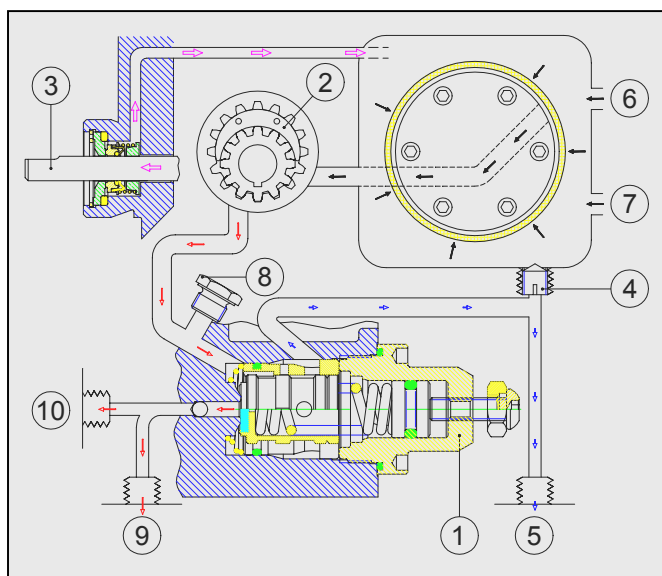

Because a vacuum now exists oil, due to atmospheric pressure, enters the suction chamber through the filter.

From the suction side the gears pass the oil to the pressure chamber, where it comes up against the head of the piston and due to the build up of pressure, forced the piston back against the pressure regulating spring. The outlet to the nozzle port, which so far has been sealed by the seat on the head of the piston, is now open and allows oil to flow through to the nozzle while the excessive oil discharges to the return side (or in by-pass in one pipe version). It will be realized of course that the spring tension, which is varied by the regulating screw (1), regulates the pressure of oil required.

On shut down, the oil pressure of course immediately drops and in this instance the spring which hitherto has been under compression, pushes the piston forward onto its seat, thereby cutting off the oil flow to the nozzle outlet (two pipe version).

In oil burner designs employing a magnetic valve in the oil line circuit, the cut-off seat on the piston head is unnecessary and in these cases a "monotube" type piston must be used in the pump. This type of piston is not fitted with a nozzle cut-off seat and its function is as a pressure regulator and safety valve, for instance for expansion of pre-heated oil.

The pump can be converted from the single pipe version to the two pipe version, fitting the by-pass plug (4) in the return port.

Pump identification

S

2

R

5

G

2

Pump type

Nozzle capacity (see graphs)

Rotation (seen from shaft end)

R = clockwise

L = counter clockwise

Pressure ranges

3 = 2 ÷ 14 bar

4 = 6 ÷ 18 bar

5 = 12 ÷ 30 bar

Factory setting

3 ±0,5 bar

10 ±0,5 bar

15(G), 20(N) ±0,5 bar

Oil Type

G = light oil

N = medium oil

Pipes system

1 = one pipe

2 = two pipes

Technical specifications

Oil viscosity	5 ÷ 300 cSt
Oil temperature	80°C max
Power consumption	See graphs
Nozzle capacity	See graphs
Nozzle line	On two sides
Suction line vacuum	0,5 bar max
Suction line pressure	0,7 bar max
Return line pressure	1,5 bar max
Rotation speed	3500 rpm max
Standard strainer.....	Light oil : stainless steel wire 140 cm ² - mesh 110µ Medium oil : stainless steel wire 140 cm ² - mesh 210µ or 330µ
Dimensions (EN 225)	Hub Ø54, shaft Ø11,1
Connections (ISO 228/1)	Inlet – Vacuum : G3/8” Nozzle port – Return port : G1/4” Pressure gauge : G1/8”
Weight	gr. 4000

Nozzle Capacity

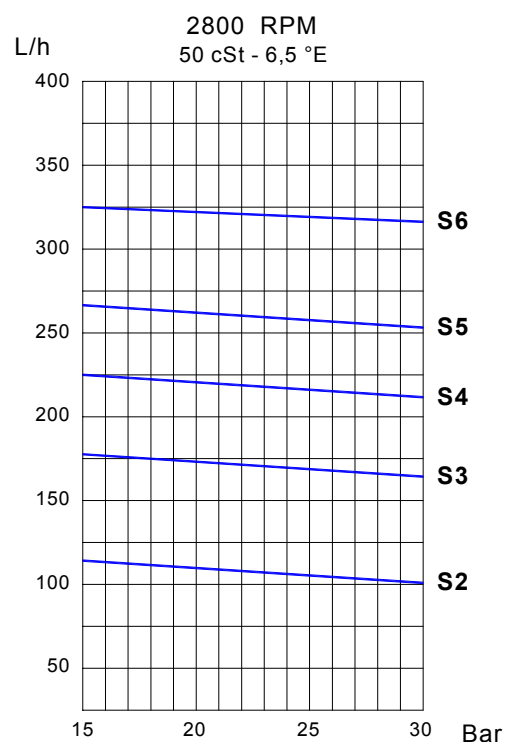
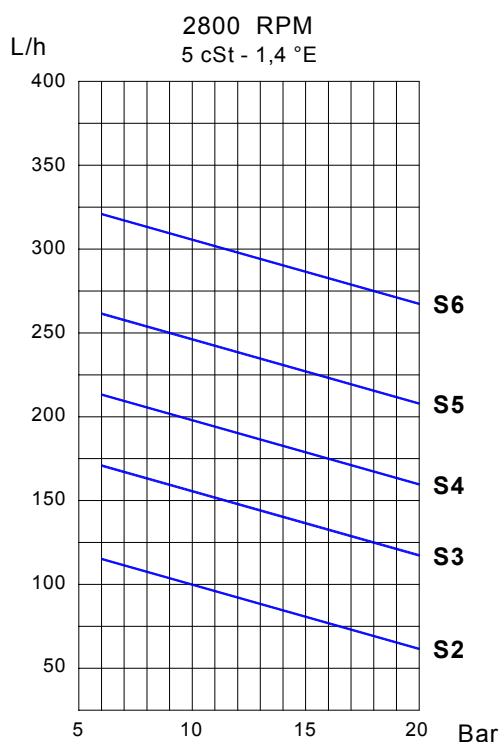

Power Consumption

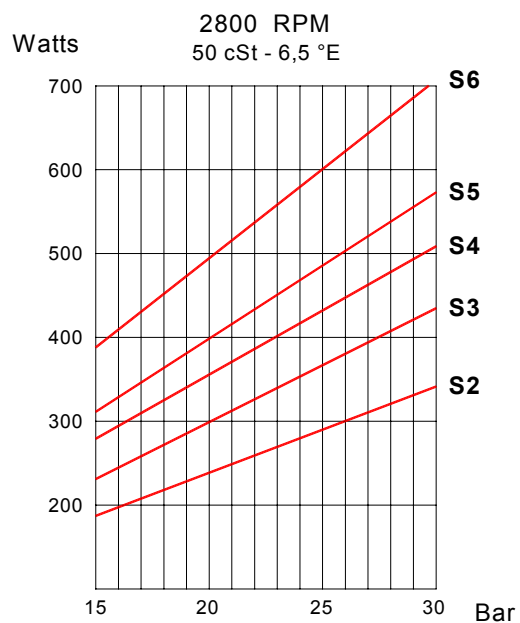
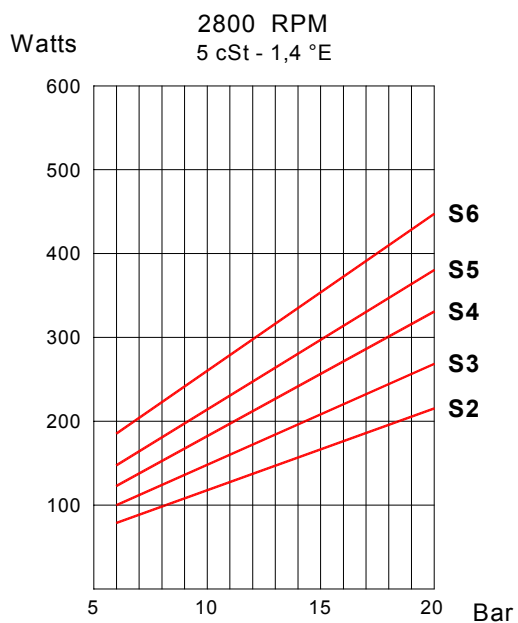

Overall Dimensions

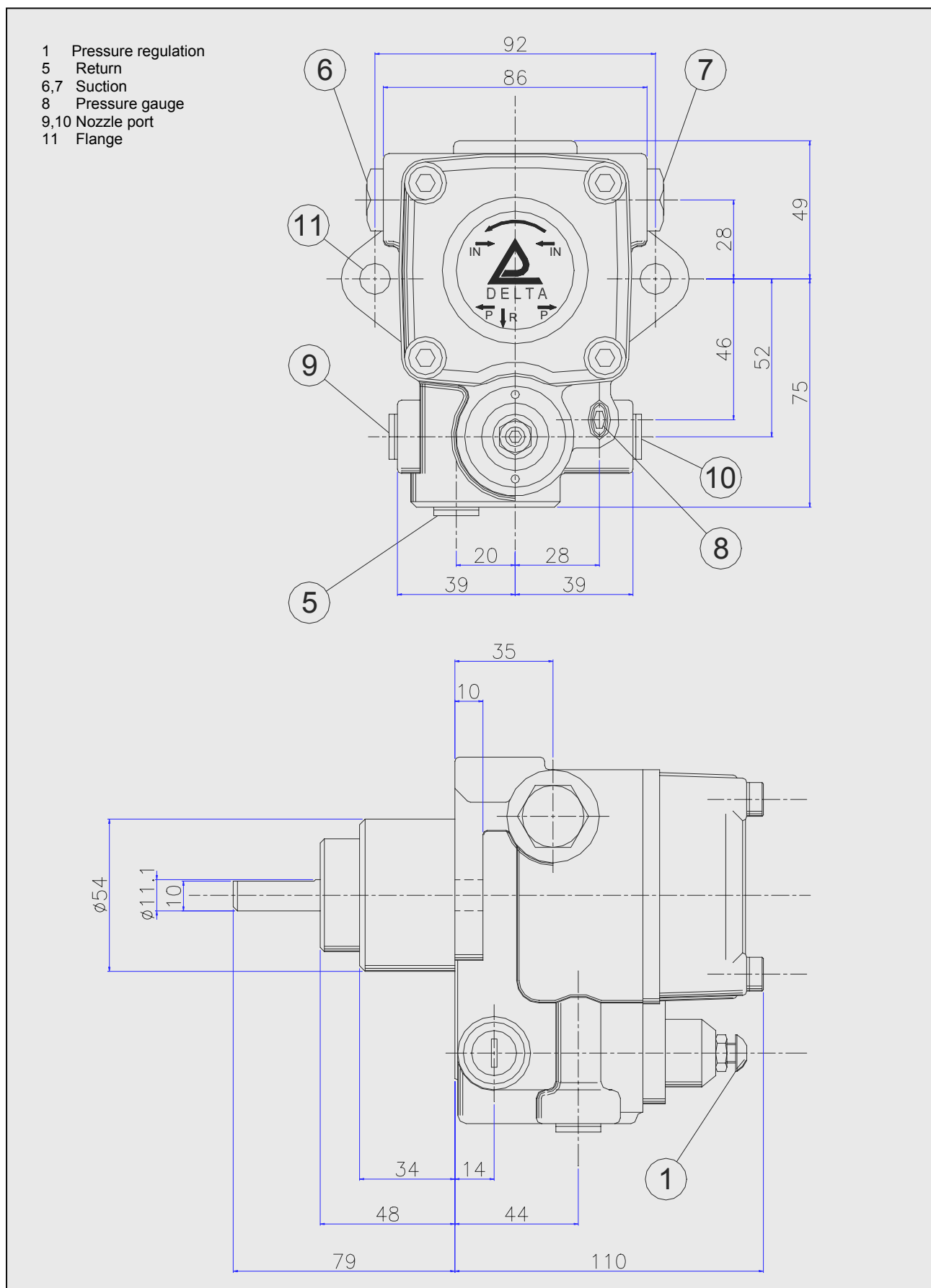

Installation and Service Instructions

Installation and Maintenance

- Make sure that the by-pass plug is not used in a single pipe installation, because the fuel unit will not function properly and damage to the pump and burner motor could result.
- Do not use fuel with additives to avoid the possible formation over time of compounds which may deposit between the gear teeth, thus obstructing them.
- After filling the tank, wait before starting the burner. This will give any suspended impurities time to deposit on the bottom of the tank, thus avoiding the possibility that they might be sucked into the pump.
- On initial commissioning a "dry" operation is foreseen for a considerable length of time (for example, when there is a long suction line to bleed). To avoid damages inject some lubrication oil into the vacuum inlet.
- Care must be taken when installing the pump not to force the pump shaft along its axis or laterally to avoid excessive wear on the joint, noise and overloading the gears.
- Pipes should not contain air pockets. Rapid attachment joint should therefore be avoided and threaded or mechanical seal junctions preferred. Junction threads, elbow joints and couplings should be sealed with removable Loctite. The number of junctions should be kept to a minimum as they are a possible source of leakage.
- Do not use PTFE tape on the suction and return line pipes to avoid the possibility that particles enter circulation. These could deposit on the pump filter or the nozzle, reducing efficiency. Always use O-Rings or mechanical seal (copper or aluminium gaskets) junctions if possible.
- Filter must be thoroughly cleaned at least once in a season to ensure correct working of the fuel unit. To remove the filter, unscrew the four screws on the cover. If the gasket between cover and pump housing should be damaged, it must be replaced.
An external filter should always be installed in the suction line upstream of the fuel unit.

CAUTION: Turn off all power before servicing any part of the system. Make sure the combustion chamber is free of oil or oil vapor before operating the system.

Nozzle Pressure Test

Most nozzles ratings are based upon 100 PSIG (6,9 bar) delivered oil pressure. The flow rate at the desired pressure must be estimated using the nozzle manufacturers data sheets.

To insure that oil is delivered to the burner nozzle at the desired pressure, do the following:

1. Remove the 1/8" plug from the pressure gauge port and connect a gauge of 0 to 30 bar or greater.
2. Start the burner motor and vent all air from the fuel unit and connected suction line system.
3. Check the adjustable nozzle pressure range of the fuel unit, using a 4 mm Allen wrench, turning the adjusting screw counter clockwise to lower the nozzle pressure and clockwise to increase the nozzle pressure.

CAUTION: Adjust the nozzle pressure in accordance with the burner manufacturers specifications.

Pipes system conversion

To convert S fuel unit from the two pipe version to the single pipe version, do the following:

1. Using a 5 mm Allen wrench, unscrew the by-pass plug from the return port.
2. Insert and screw a 1/4" plug into the return port.

CAUTION: In the two pipe version the piston performs a positive nozzle cut-off and the air is bled through the return port. After the conversion, the air must be bled manually, through the pressure gauge.

Nozzle Cut-Off Test (two pipe)

Fuel oil is not compressible but air is. Air trapped in the nozzle line, anywhere between the fuel units nozzle port and the nozzle itself, will compress during burner operation. Following burner shutdown, any trapped compressed air will expand displacing the oil in the nozzle line, forcing continued oil flow through the nozzle that will, in effect, falsely appear to be poor fuel unit Cut-Off. This occurrence is particularly common with low flow rate nozzles used in conjunction with long air tubes. Moreover, operating characteristics of burner motors may vary by manufacturer, model and operative speed. Some motors, especially older ones, take an exceptionally long time to wind down; and those that do, since the fuel unit turns with the motor, may falsely give the appearance of poor fuel unit Cut-Off.

To verify positive nozzle Cut-Off after burner shutdown, do the following:

1. Remove the nozzle line and fitting from the nozzle port of the fuel unit and connect a 1/4" pressure gauge to the nozzle port (a gauge of 30 bar or greater be used). It may be more convenient to use a gauge fitted out with an extension nipple or with a line and flare nut to connect directly to the fitting installed into the nozzle port. If any type of extension is used between the nozzle port and the gauge, it should be kept as short as possible to minimize the amount of trapped air.
2. Start the burner motor and vent all air from the fuel unit and connected suction line system. Record the nozzle pressure reading on the gauge.
3. Shut off the burner motor. Initially the pressure will drop and then stabilize within a second or two. The pressure reading on the gauge should stabilize at 80% or greater of the adjusted pressure (the pressure recorded above) and hold for at least two minutes.

Vacuum Test

The vacuum test is necessary to verify the fuel unit's suction ability, to evaluate the leak tight integrity of the entire fuel unit and connected oil suction line piping system, to confirm that there are no abnormal restrictions in the oil suction line system, and, to confirm that the system vacuum is within the allowable specification limits of the unit. Please watch in any case the graphs for maximum suction line length depending on line diameter, viscosity, difference in height of suction line and pump or nozzle capacity. To perform the test, do the following:

1. Remove the 3/8" plug from the unused inlet port and connect a vacuum gauge to this port.
2. Start the burner motor and vent all air from the fuel unit and connected suction line system.
3. With the burner motor running, close the valve connected to the inlet port. You will note that the vacuum as measured by the vacuum gauge will increase. Allow the burner motor to continue to run until the highest vacuum reading is achieved. A fully primed fuel unit in good condition should be capable of pulling at least 0,7 bar. If not, before condemning the fuel unit, be sure that all connections and plugs are tight, the cover gasket is in good condition and the valve is in good working order.
4. Shut off the burner motor. Initially, the vacuum reading will drop and then stabilize within a second or two. Once the vacuum reading stabilizes, record the reading. If the fuel unit is free of leaks, this reading should hold constant for at least 2 minutes. If the vacuum reading drops, there is a leak that must be located and corrected.
5. When each leakage is removed and the valve onto suction line is open, check to be sure that the actual operating vacuum does not exceed 0,5 bar.