



Oil burners fuel unit with pressure regulating Type CV, SV2

www.deltapumps.com



CV2



Oil burners fuel unit with pressure regulating

Type CV, SV2

The DELTA fuel unit is an efficient modern oil burner pump with compact design and since its mounting flange, hub and shaft sizes are manufactured to international standard, it can be fitted to every oil burner. It has the following features:

Features

- High suction capability. (9" Hg - single pipe; 15" Hg - two pipe)
- Self priming (two pipe version).
- Reliable pressure and effective cut-off.
- Special shaft seal.
- Silent operation.
- Low power absorption.
- Easily installed and adjusted.
- Pressure and vacuum gauge ports.
- Easy air bleeder valve.
- High RPM cut-off (SV2 model).
- Clear bleeder tube provided.

Applications

- For pumping oil in high pressure oil burners and transfer pump applications.
- For use with kerosene, K1, #1 or #2 fuel oil.
- 3450 RPM and 1725 RPM operating speeds.
- For use with gravity feed or lift applications.
- Suitable for a one or two pipe system.
- For use with firing rates up to 32 gph at 100 psi.
- For use with nozzle pressures up to 300 psi.
- For hub or flange mounting.
- Must not be used to pump water or acid (voids warranty).

Operation

The fuel unit, consists of a pump, filter and pressure regulator/cut-off valve housed within one casting. The pumping action is obtained from two spur gears, one of which is connected to the drive shaft. The pump casting provides the various oil ways, for the supply and return ports.

Pressure and vacuum gauge ports are also provided. The unit is available in two pipe version (self priming) and in a single pipe version (manual priming).

On start up, the rotating gears purge the air from the suction chamber, through a vent groove in the piston to the return line in the two pipe version. In the single pipe version air must be bled at the bleeder port. Because a vacuum now exists oil, due to atmospheric pressure, enters the suction chamber through the filter.

On new installations, it is easier to bleed the air more quickly, through the air bleeder port.

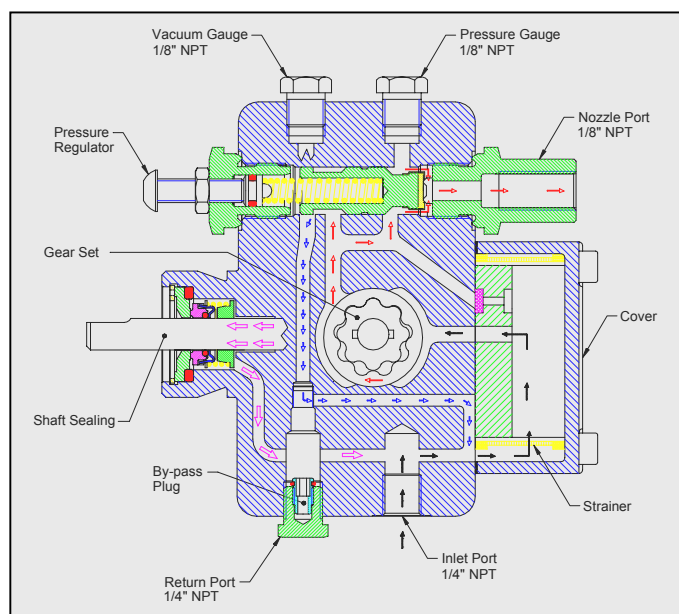

Fig. 1

From the suction side, the gears pass the oil to the pressure chamber, where it comes up against the head of the piston. Due to the build up of pressure, the piston is forced back against the pressure regulating spring. The outlet to the nozzle port, which so far has been sealed by the seat on the head of the piston, opens and allows oil to flow through to the nozzle while the excess oil discharges to the return side (or by-passes in the one pipe version). It should be noted that the spring tension, which is varied by the regulator screw, regulates the oil pressure.

On shut down, the oil pressure drops and the spring, which has been under pressure, pushes the piston forward onto its seat, thereby cutting off the flow of oil to the nozzle outlet.

The SV2 model is provided with an additional internal valve, which allows an efficient cut-off, because no oil reaches the piston when the motor's RPM drops.

Approvals

Listed by Underwriter's Laboratory
Standard UL343 - File nr. MH12779

Pump identification	CV	1	R	R	2	4	
Pump type CV SV							
Nozzle capacity (see graphs)							
Rotation (seen from shaft end) R = clockwise L = counter clockwise							
Nozzle line (seen from shaft end) R = right L = left							
Pipes system 1 = one pipe 2 = two pipe							
Pressure ranges 3 = 30 ÷ 145 psi 4 = 58 ÷ 215 psi (Standard) 5 = 115 ÷ 285 psi							
Factory setting 58 ±4 psi 100 ±4 psi 215 ±4 psi							

Technical Specifications

Oil viscosity	32 ÷ 225 SSU
Oil temperature	140°F max
Oil types	Suitable for kerosene, K1, #1 or #2 fuel oil and waste oil
Power consumption	See graphs
Nozzle capacity	See graphs
Suction line vacuum	4.40 psi (9 inHg) max for single-pipe installation 7.35 psi (15 inHg) max for two-pipe installation
Suction line pressure	10 psi max
Return line pressure	21 psi max
Rotation	Clockwise / Counter Clockwise 3450 RPM or 1725 RPM
Standard strainer	Stainless steel mesh 110 microns, 10 Sq.In.
Dimensions	Hub dia. 1"¼, shaft dia. 5/16" Flange hub dia. 2"1/8
Connections	Inlet – return port: 1/4"NPT Nozzle port : 1/8"NPT Pressure – vacuum gauge : 1/8"NPT
Weight	2.66 lb

Diagrams

NOZZLE CAPACITY

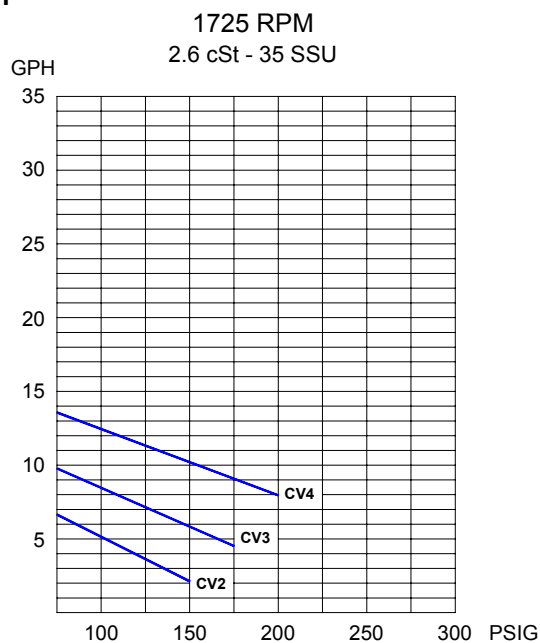
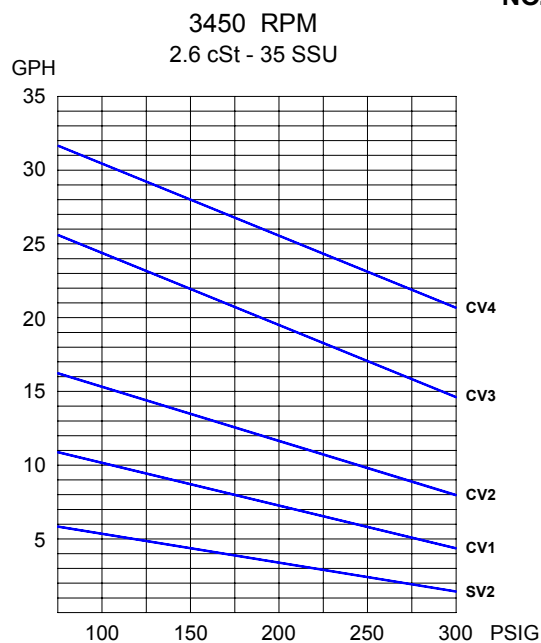

POWER CONSUMPTION

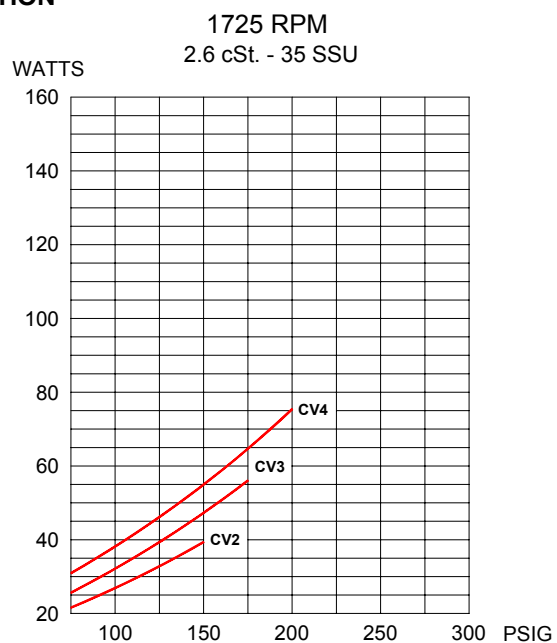
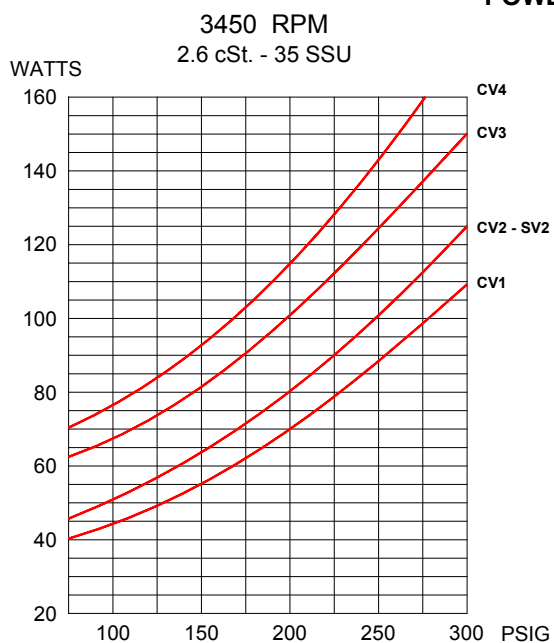

Overall dimensions

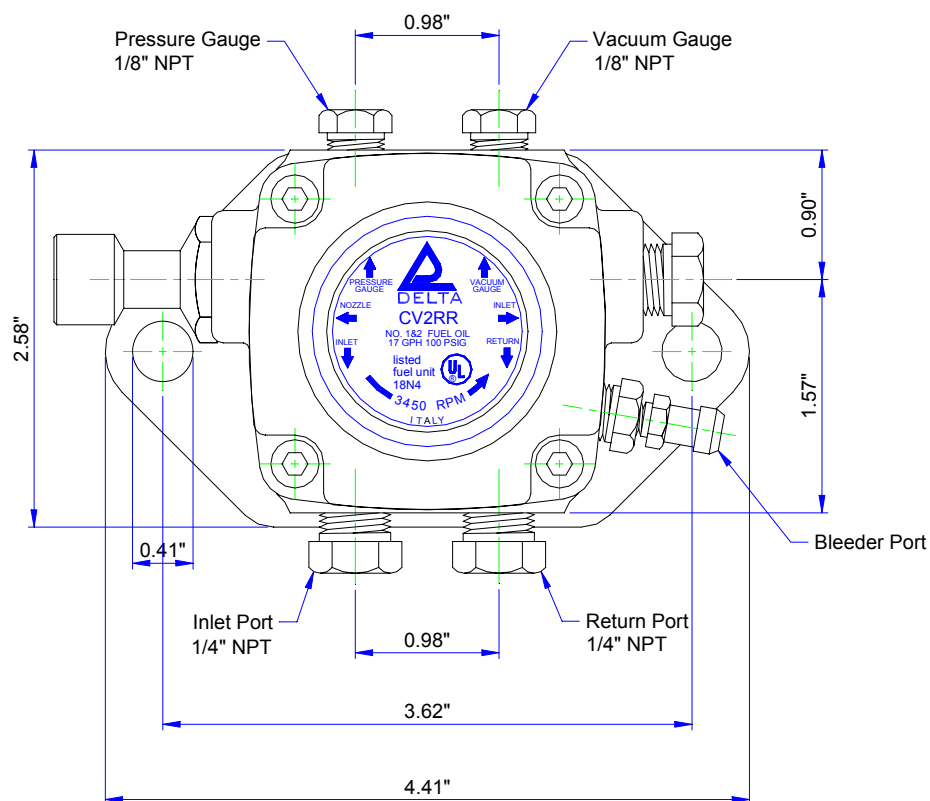
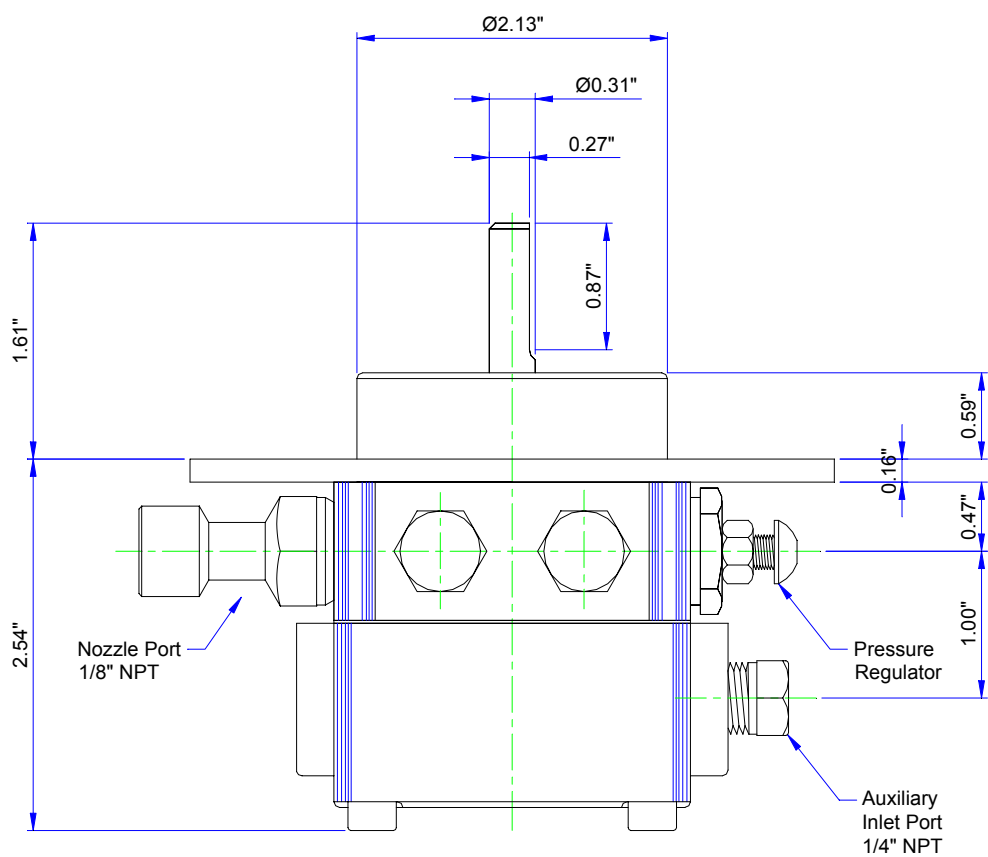

By-pass installation

To convert the DELTA fuel unit from the single pipe version to the two pipe version, do the following:

- Using a 9/16" wrench, remove the 1/4"NPT plug from return port (Fig. 2).
- Located inside the 9/16" return plug is the 5/32" by-pass plug. Remove it with an Allen wrench (Fig.3).
- Insert the 5/32" by-pass plug in the return port of the pump (Fig. 4).

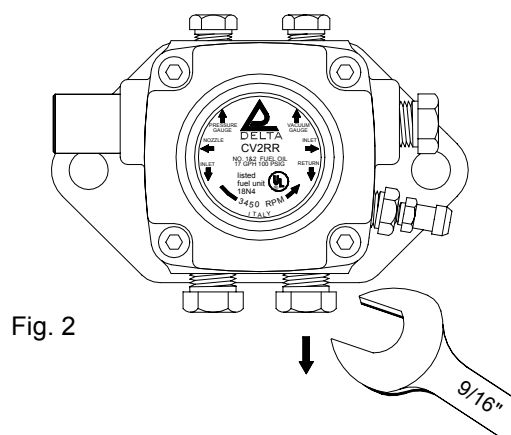

Fig. 2

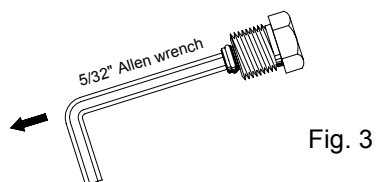

Fig. 3

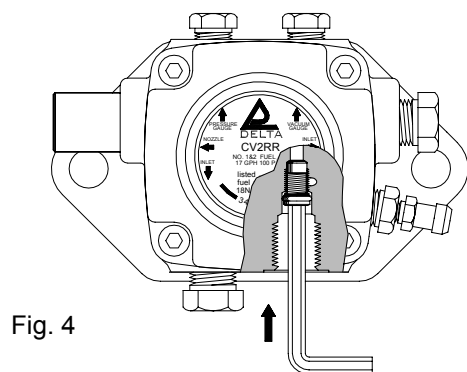

Fig. 4

To convert the DELTA fuel unit from the two pipe version to the single pipe version, do the following:

- Using a 5/32" Allen wrench, unscrew the by-pass plug from the return port.
- Insert and screw a 1/4"NPT plug into the return port.

CAUTION: In a two pipe installation, the pump is self priming and the air is bled through the return port. When the pump is converted into a single pipe version, the air must be bled manually, through the bleeder port.

General information

- Make sure that the by-pass plug is not used in a single pipe installation, because the fuel unit will not function properly and damage to the pump and burner motor could result.
- All oil line connections must be air tight. Use only flare fittings or threaded connections. The use of compression fittings is not recommended.
- Keep the number of oil line fitting to a minimum. Each fitting is a potential source for leaks.
- Use only pipe thread compound approved for use with oil. The use of PTFE tape is not permitted. Teflon tape can cause fuel unit failure and will void its warranty.
- To comply with "NFPA Bulletin 31" the inlet line pressure must not exceed 3 psig. For gravity feed systems and systems which employ a pumping system upstream of the burner fuel unit, the inlet line pressure must be checked.
- Suitable for use with 3/8" or 1/2" lines.
- The DELTA fuel unit is equipped with an internal 110 micron strainer that requires periodic replacement. However, an external strainer must be installed upstream to the fuel unit.
- To service, use calibrated pressure and vacuum gauges.

CAUTION: In a single pipe installation, the pump is not self priming, and the air must be bled manually, through the bleeder port. When the pump is converted into a two pipe version, it becomes self-priming, because the air is bled back through the return port.

Installation and Service Instructions

Installation and Maintenance

- Make sure that the by-pass plug is not used in a single pipe installation, because the fuel unit will not function properly and damage to the pump and burner motor could result.
- Do not use fuel with additives to avoid the possible formation over time of compounds which may deposit between the gear teeth, thus obstructing them.
- After filling the tank, wait before starting the burner. This will give any suspended impurities time to deposit on the bottom of the tank, thus avoiding the possibility that they might be sucked into the pump.
- On initial commissioning a dry operation is foreseen for a considerable length of time (for example, when there is a long suction line to bleed). To avoid damages inject some lubrication oil into the vacuum inlet.
- Care must be taken when installing the pump not to force the pump shaft along its axis or laterally to avoid excessive wear on the joint, noise and overloading the gears.
- Pipes should not contain air pockets. Rapid attachment joint should therefore be avoided and threaded or mechanical seal junctions preferred. Junction threads, elbow joints and couplings should be sealed with removable Loctite™. The number of junctions should be kept to a minimum as they are a possible source of leakage.
- Do not use PTFE tape on the suction and return line pipes to avoid the possibility that particles enter circulation. These could deposit on the pump filter or the nozzle, reducing efficiency. Always use O-Rings or mechanical seal (copper or aluminium gaskets) junctions if possible.
- To clean the filter remove the cover. It must be thoroughly cleaned at least once in a season to ensure correct working of the fuel unit. The filter must be mounted with the supporting legs leaned against the pump body. If the joint plate between cover and pump housing should be damaged, it must be replaced. An external filter should always be installed in the suction line upstream of the fuel unit.
- Make sure the combustion chamber is free of oil or oil vapor before operating the system.

CAUTION: Turn off all power before servicing any part of the system.

Nozzle Pressure Test

Most nozzles ratings are based upon 100 PSIG delivered oil pressure. The flow rate at the desired pressure must be estimated using the nozzle manufacturers data sheets.

To insure that oil is delivered to the burner nozzle at the desired pressure, do the following:

1. Remove the 1/8" plug from the port marked "P" and connect a pressure gauge to this port (use a gauge of 0 to 300 PSIG or greater). The "P" port (Pressure Gauge Test Port) has been provided specifically for the connection of the pressure gauge for measuring the nozzle pressure; however, when available, it is also permissible to use the vent port for measuring nozzle pressure.
2. Start the burner motor and vent all air from the fuel unit and connected suction line system.
3. Check the adjustable nozzle pressure range of the fuel unit, using a 4 mm Allen wrench, turning the adjusting screw counter clockwise to lower the nozzle pressure and clockwise to increase the nozzle pressure.

CAUTION: Adjust the nozzle pressure in accordance with the burner manufacturers specifications.

Nozzle Cut-Off Test

Fuel oil is not compressible but air is. Air trapped in the nozzle line, anywhere between the fuel units nozzle port and the nozzle itself, will compress during burner operation. Following burner shutdown, any trapped compressed air will expand displacing the oil in the nozzle line, forcing continued oil flow through the nozzle that will, in effect, falsely appear to be poor fuel unit Cut-Off. This occurrence is particularly common with low flow rate nozzles used in conjunction with long air tubes. Moreover, operating characteristics of burner motors may vary by manufacturer, model and operative speed. Some motors, especially older ones, take an exceptionally long time to wind down; and those that do, since the fuel unit turns with the motor, may falsely give the appearance of poor fuel unit Cut-Off.

To verify positive nozzle Cut-Off after burner shutdown, do the following:

1. Remove the nozzle line and fitting from the nozzle port of the fuel unit and connect a 1/8" pressure gauge to the nozzle port (a gauge of 300 PSIG or greater be used). It may be more convenient to use a gauge fitted out with an extension nipple or with a line and flare nut to connect directly to the fitting installed into the nozzle port. If any type of extension is used between the nozzle port and the gauge, it should be kept as short as possible to minimize the amount of trapped air.
2. Start the burner motor and vent all air from the fuel unit and connected suction line system.
3. Record the nozzle pressure reading on the gauge.
4. Shut off the burner motor. Initially the pressure will drop and then stabilize within a second or two. The pressure reading on the gauge should stabilize at 80% or greater of the adjusted pressure (the pressure recorded above) and hold for at least two minutes.

Vacuum Test

The vacuum test is necessary to verify the fuel unit's suction ability, to evaluate the leak tight integrity of the entire fuel unit and connected oil suction line piping system, to confirm that there are no abnormal restrictions in the oil suction line system, and, to confirm that the system vacuum is within the allowable specification limits of the unit. Please watch in any case the graphs for maximum suction line length depending on line diameter, viscosity, difference in height of suction line and pump or nozzle capacity. To perform the test, do the following:

1. Remove the 1/8" plug from the port marked "V" and connect a vacuum gauge to this port.
2. Start the burner motor and vent all air from the fuel unit and connected suction line system.
3. With the burner motor running, close the valve connected to the inlet port. You will note that the vacuum as measured by the vacuum gauge will increase. Allow the burner motor to continue to run until the highest vacuum reading is achieved. A fully primed fuel unit in good condition should be capable of pulling at least 20 InHg. If not, before condemning the fuel unit, be sure that all connections and plugs are tight, the cover gasket is in good condition and the valve is in good working order.
4. Shut off the burner motor. Initially, the vacuum reading will drop and then stabilize within a second or two. Once the vacuum reading stabilizes, record the reading. If the fuel unit is free of leaks, this reading should hold constant for at least 2 minutes. If the vacuum reading drops, there is a leak that must be located and corrected.
5. When each leakage is removed and the valve onto suction line is open, check to be sure that the actual operating vacuum does not exceed 15 InHg