

## VMM

**Multiple safety solenoid valve  
for Gas regulating trains  
DN32 ... DN50**

[www.elektrogas.com](http://www.elektrogas.com)



VMM402AS30

# VMM

## Multiple safety solenoid valve for gas regulating trains

Class A - Group 2

The VMM type valve is a combination of two solenoid valves in an only compact and versatile valve housing.

This device is suitable for air or gas blocking and releasing controls (with one or two stages operation), required in gas power burners, atmospheric gas boiler, furnaces and others gas consuming appliances.

The VMM type valve is made in accordance with EN161 standard (EC type examination certificate nr. 0063AQ1350).

### 1- Features

- ❑ Inlet/outlet connection flanges are easy detachable to simplify the installation.
- ❑ Provided with bilateral G1/4" pressure gauges in all pressure chambers.
- ❑ Optional G1/8" connection for closed position indicator micro switch.
- ❑ Fine mesh filter incorporated prevents dirty contamination of the seal seat.
- ❑ Maximum operating pressure 200 mbar or 360 mbar.
- ❑ Suitable for air and non-aggressive gases (EN 437, 1, 2 and 3 families).
- ❑ Easy adjustable flow rate, fast stroke and slow opening time.
- ❑ Qualified for continuous service (100% ED) and endless ON/OFF cycles.
- ❑ Coil insulation is class H (180°C).
- ❑ Terminal box with PG connector.
- ❑ Provided with a power saving electronic device, to reduce power consumption and working temperature.
- ❑ Valves are 100% tested by computerized testing machineries and are fully warranted.
- ❑ For valve identification see the following charts.

### WARNING

- This control must be installed in compliance with the laws in force.
- Read instructions before use.
- Elettromeccanica Delta S.p.a. reserves the right to update or make technical changes without prior notice.

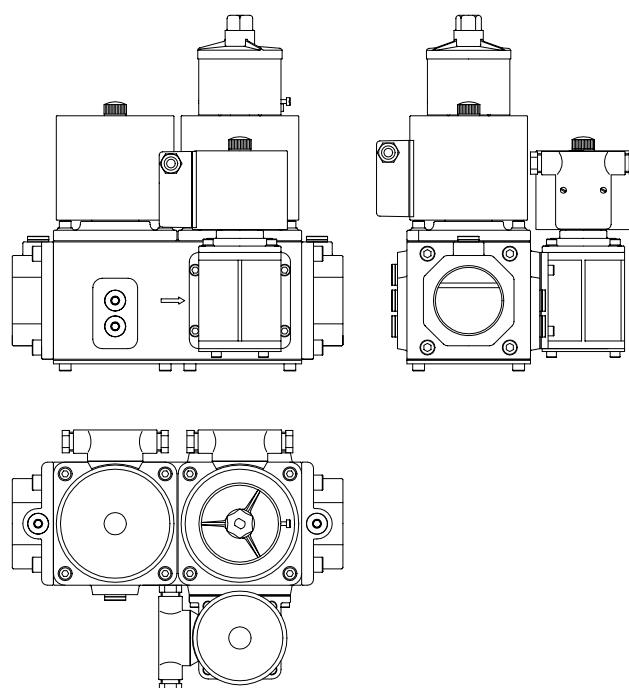

Fig. 1

### 2- Technical specifications

<i>Connections</i> .....	Gas threaded ISO 7/1 Rp1"¼, Rp1"½ and Rp2"
<i>By-pass size</i> .....	1/2" and 1"
<i>Voltage rating</i> .....	230 VAC 50/60 Hz
<i>Voltage on request</i> .....	110 VAC 50/60 Hz
<i>Voltage tolerance</i> .....	-15% / +10%
<i>Power consumption</i> .....	90W (working) by-pass 1/2" 25W by-pass 1" 45W
<i>Max. opening current</i> .....	2A for 1sec.
<i>Environment temperature</i> .....	-15°C / +60°C
<i>Max. working pressure</i> .....	200 / 360 mbar
<i>Flow capacity</i> .....	see charts
<i>Seal</i> .....	NBR
<i>Closing time</i> .....	< 1 sec.
<i>Protection class</i> .....	IP 54 (EN60529)
<i>Cable gland</i> .....	PG9
<i>Overall dimensions</i> .....	see charts

### 3- Operation

The VMM type valve is a safety shutting device using auxiliary power supply.

The first valve (A) is a fast opening solenoid valve that is safety. When it is de-energized, the spring pushes on the seal disc, keeping the gas passage closed. Now, the inlet chamber is under the gas line pressure, and it forces on the disc too, improving the seal.

When the coil is powered the valve opens rapidly, against the strength of the spring and gas pressure.

If the power supply is shut off, the valve rapidly closes, interrupting the gas flow.

Equally, the second valve (B) may be a fast opening or a slow opening solenoid valve to adjust the gas flow, with a first adjustable fast stroke and a second adjustable slow stroke (see the *Service Instruction Section*).

It is possible connect a third by-pass valve (C), which performs by driver stage or to obtain a second fast (slow) stroke or both.

### 4- Accessories

A fine mesh filter is provided, to prevent dirty contamination of the seal seat. However, an external strainer must be installed upstream of the unit.

Each pressure chamber is provided with bilateral G $\frac{1}{4}$ " gauges, to connect min/max adjustable pressure switches, leakage tester or other gas equipments.

On request, valves are supplied with a G $\frac{1}{8}$ " connection on the bottom, to installed a closed position indicator micro switch. An adapting rod is provided too.

### WARNING

**The assemblage of any accessories could exclude the fitting of other devices.**

### 5- Coil features

The continuous service (100% ED) causes inevitable coil heating, depending of working environment. This situation is absolutely normal and has not to worry. To improve the coil cooling, install the unit allowing free air circulation.

Valve is provided with a power saving electronic device. It has two stages of operation: full power is supplied to the coil while the valve is opening; low power is supplied while the valve is open.

Coil and terminal box are provided with suitable gaskets, to avoid water and dirty contamination (see the *Service Instruction Section*).

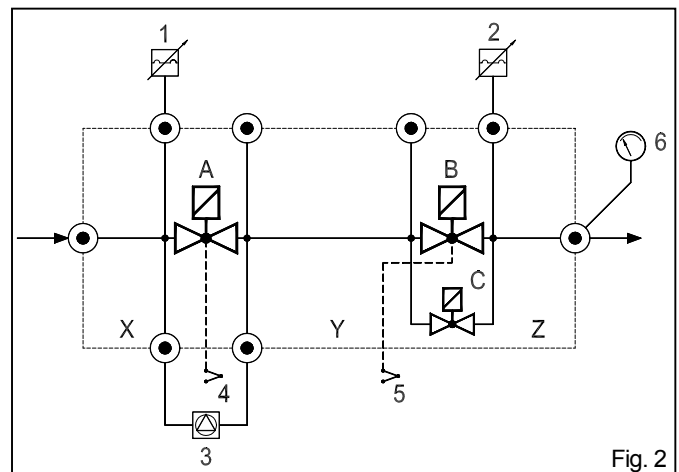

- 1 = Adjustable pressure switch (Min)
- 2 = Adjustable pressure switch (Max)
- 3 = Valve leakage tester
- 4 = Limit switch
- 5 = Limit switch
- 6 = Burner pressure gauge

- A = First valve
- B = Second valve
- C = By-pass valve
- X = Inlet chamber
- Y = Middle chamber
- Z = Outlet chamber

### 6- General information

Backpressure sealing is compliant with the *Class A*: the maximum backpressure admitted, with leakage within the EN161 requirements, is 150mbar.

Maximum torsional stresses admitted are compliant with the *Group 2* of the EN161 standard.

All components are design to withstand any mechanical, chemical and thermal condition occurring during typical service.

Effective impregnation and surface treatments has been used to improve mechanical sturdiness, sealing and resistance to corrosion of the components.

Valves are suitable for use with air and non-aggressive gases included in the 1, 2 and 3 families (EN 437).

- Materials used:
- Aluminium
  - Brass
  - Stainless steel
  - Nitrile rubber (NBR)
  - Ethylene propylene (EPDM)
  - Fluoroelastomer (FPM)
  - PTFE

## 7- Valve identification

	VMM	50	2	A	S	1	0
<b>Valve type</b>							
<b>Connections size</b> 32 = 1 1/4" (DN32) 40 = 1 1/2" (DN40) 50 = 2" (DN50)							
<b>Max working pressure</b> 2 = 200 mbar 3 = 360 mbar							
<b>Supply voltage</b> A = 230V 50/60Hz B = 110V 50/60Hz							
<b>Second valve type</b> F = fast S = slow							
<b>By-pass valve on the Right side</b> (seen from the inlet) 0 = none 1 = 1/2" (DN15) Fast 2 = 1/2" (DN15) Slow 3 = 1" (DN25) Fast 4 = 1" (DN25) Slow							
<b>By-pass valve on the Left side</b> (seen from the inlet) 0 = none 1 = 1/2" (DN15) Fast 2 = 1/2" (DN15) Slow 3 = 1" (DN25) Fast 4 = 1" (DN25) Slow							

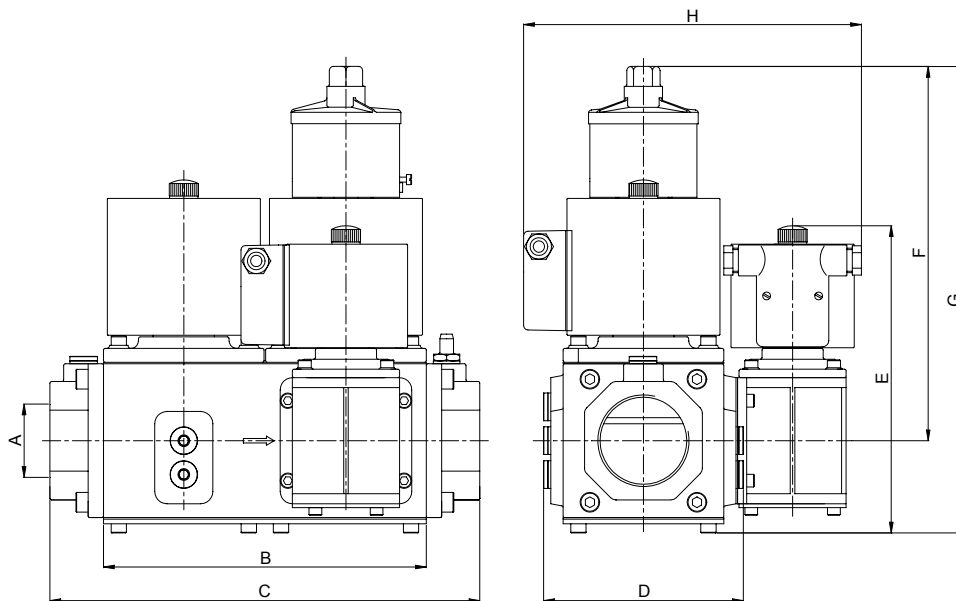

Model	Overall dimensions (mm)								Weight (Kg)
	A	B	C	D	E	F	G	H	
VMM....F00	Gas threaded according to ISO 7/1	211	280	105	138	170	230	148	13,0
VMM....S00		211	280	105	138	245	305	148	13,7
VMM....S10		211	280	105	138	245	305	200	15,3
VMM....S20		211	280	105	138	245	305	200	15,5
VMM....S30		211	280	105	138	245	305	220	16,3
VMM....S40		211	280	105	138	245	305	220	16,5

## 8- Loss of pressure

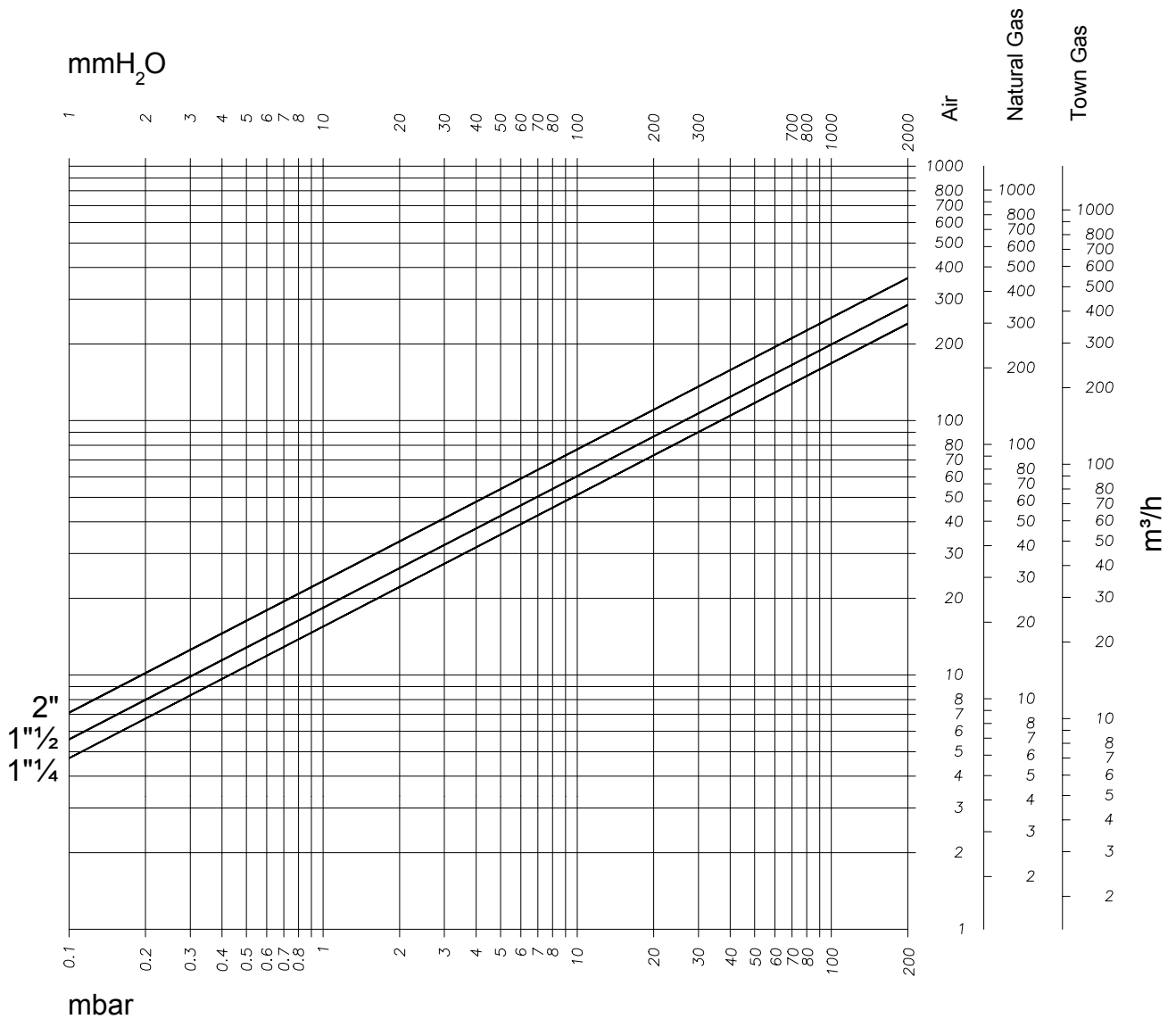

### Formula of conversion from air to other gases

Gas type	Specific gravity (Kg/m <sup>3</sup> )	K
Natural Gas	0.80	1.25
Town Gas	0.57	1.48
LPG	2.08	0.77
Air	1.25	1.00

+15°C, 1013 mbar, dry

$$V_{\text{AIR}} = \frac{V_{\text{GAS TO BE USED}}}{K}$$

$$K = \sqrt{\frac{\text{AIR SPECIFIC GRAVITY}}{\text{GAS SPECIFIC GRAVITY}}}$$

## 9- Valve installation

Verify the line pressure is lower of the maximum working pressure admitted to the valve.

Check correspondence of flow direction with arrow printed on valve body.

Check correct alignment of connecting pipes and allow enough space from the walls to allow free air circulation.

**Make sure no foreign body is entered into the valve during handling.**

**Install in an area that is protected from rain and water splashes or drops.**

1. Put sealing agent onto the pipe thread (avoid excessive quantities of fittings glue which could enter in the valve and damage the seal seat).
2. Screw the pipes using proper tools only. Do not use unit as lever because damage to the valve stem could result. Remove connection flanges to simply installation.

**Avoid overtightening and mount tension free.**

Following chart shows the maximum values of bending moment ( $F_{max}$ ) and torque ( $T_{max}$ ), according with EN13611.

DN	$F_{max}$ (Nm) $t < 10$ s	$T_{max}$ (Nm)
1"¼	475	160
1"½	610	200
2"	1100	250

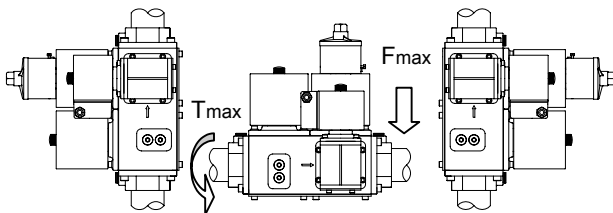

Valve may be mounted with coil in horizontal or vertical position. Coil may be oriented 360 degrees in any direction.

## 10- Electrical connections (IEC 730-1)

Check correspondence between valve voltage rating and line power supply, before making any electrical connections.

1. Switch off power supply and remove protection cover.
2. Connect power cables to rectifier circuit terminal board.
3. Should cables pass through originally closed opening, use the rubber disc placed underneath the box plug to close any other opening.
4. Screw back the box cover, taking care to use all gaskets properly, because this could condition the valve life duration.

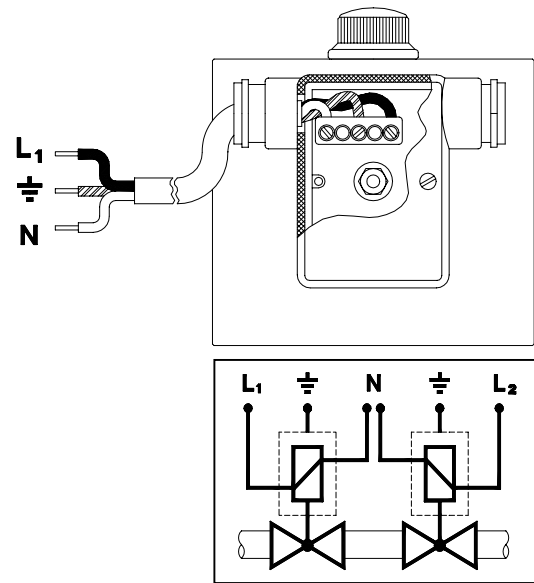

Fig. 5

### WARNING

- To prevent product damage and dangerous situations, read the Installation and Service Instructions carefully.
- Turn off all power before servicing any part of the system.
- Perform leak and functional tests after mounting. A gas leak detection spray may be used also.
- Coil and terminal box must be replaced with identical spare parts only.
- If the coil is turned, make sure the cap (brake) is properly tightened and the coil is locked.
- Use all gaskets properly (void warranty).
- All wiring must be in compliance with local and national codes.
- Make sure all works are performed by qualified technicians only.

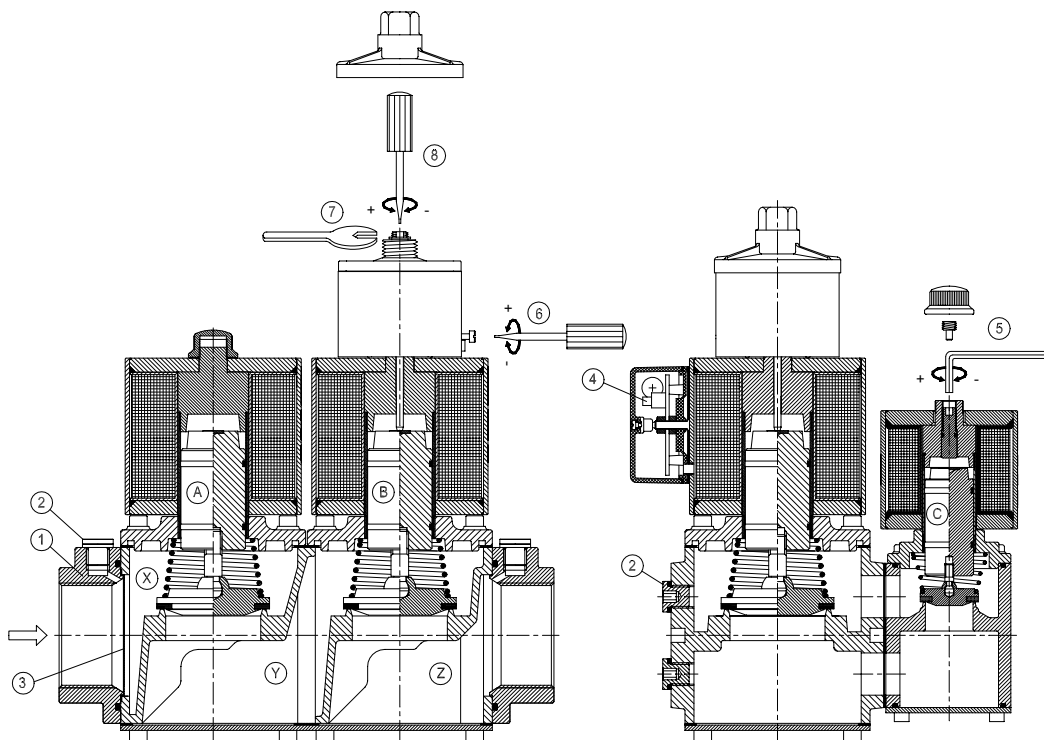

Fig. 6

- 1 = Connection flange
- 2 = G1/4" pressure gauge
- 3 = Filter
- 4 = Electrical connections
- 5 = By-pass flow adjustment
- 6 = Opening time adjustment (T)
- 7 = Rapid stroke adjustment (Vstart)
- 8 = Flow adjustment (Vmax)

- A = First valve
- B = Second valve
- C = By-pass valve
- X = Inlet chamber
- Y = Middle chamber
- Z = Outlet chamber

### 11- Flow rate adjustment (Vmax)

Flow rate may be adjusted from 0 cubic meters/h up to the maximum admitted:

#### Fast valve type

1. Remove coil fastener cap.
2. Using a 4 mm Allen wrench, remove the locking dowel.
3. Located under the locking dowel is the flow regulation screw. Use the Allen wrench to set it.
4. Turn wrench clockwise to decrease or counter-clockwise to increase flow rate (factory setting is max. flow rate).
5. When adjustment is completed, screw back the locking dowel and cap.

#### Slow valve type

1. Remove plastic cap.
2. Keeping the outer screw fixed, use a screw driver to turn the internal screw clockwise to decrease or counter-clockwise to increase flow rate (factory setting is max. flow rate).
3. When adjustment is completed, screw back the plastic cap.

### 12- Fast stroke adjustment (Vstart)

Fast flow section may be adjusted:

1. Remove plastic cap.
2. Using a 7 mm wrench, turn the outer screw clockwise to decrease or counter-clockwise to increase the initial fast stroke.
3. When adjustment is completed, screw back the plastic cap.

NOTE: the flow rate regulation can not be lower than the fast flow section.

### 13- Opening time adjustment (T)

To regulate opening time, turn the screw located on the side of the brake. One fourth of a turn clockwise increases opening time by 2÷3 s, up to a maximum of about 25 s (slow run).

Factory setting is about 12÷14 s.

### WARNING

- In the slow valve type, perform the fast stroke adjustment before of the flow rate adjustment.
- Make sure that capacity adjustments are made while burner is working.
- Check the regulation is not changed during reassembly.
- Adjustments below 40% of capacity are unadvisable because they may cause turbulence.