

UV PHOTOTUBES

FLAME SENSOR FOR GAS BURNER

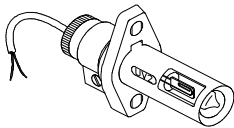

Introduction

Flame detection in burners occurs by means of sensors detecting the presence of flame through an electrical signal, which can be used by ignition and control devices. UV phototubes exploit ultra-violet radiation emitted by the light generated by the flame; they are especially suitable for appliances in which very dissimilar fuels (e.g. liquid and gaseous fuels) are used.

Features

These sensors are used for flame detection in gas and mixed fuel (gas and oil) burners. UV phototubes consist of a glass bulb filled with gas, containing two electrodes suitably shaped. When supplying both electrodes with AC voltage, if an ultra-violet electromagnetic radiation (range from 190 to 290 nm) hits the phototube, the electrons, emitted by the negative biased electrode and captured by the positive biased one, start an ionization process leading to the generation of an electric discharge and hence to the production of electric current.

Two phototube models are available, called UV1 and UV2 as shown in Fig. 1, and having different sensitivity (which is higher in the case of the UV1) and different overall dimensions. Fig. 1 also shows the drilling plane to be carried out in order to install flame sensors, which are provided with standard 600 mm long connection cable.

To prevent possible problems due to the ageing of the sensitive element, it is advisable to replace it after about 100,000 operating hours. These phototubes are not sensitive to daylight, therefore they do not need any special shielding, unless they are placed near gas discharge lamps (neon or similar), the light of which may have a negative influence on their operation.

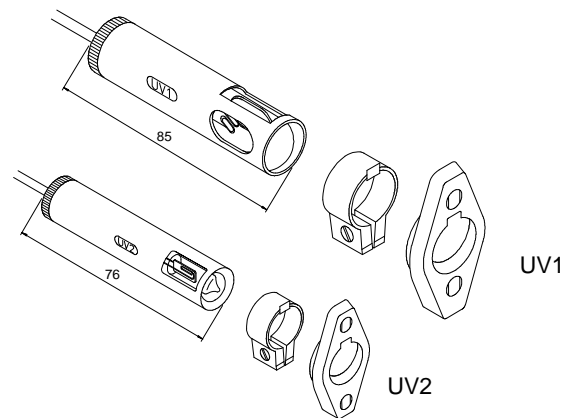
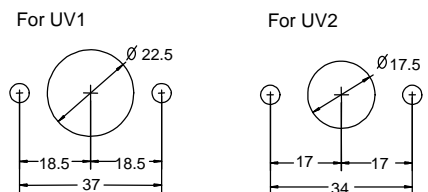

Fig. 1



ERGIO CONTROLES
 La Rioja 511
 Cordoba, Argentina. CP: X5000EVK
 Tel: 0351-4250787
<http://www.ergiocontroles.com>
 E-mail : ergiocontroles@ergiocontroles.com