

PHOTOCELLS

FLAME SENSORS FOR FUEL OIL BURNERS

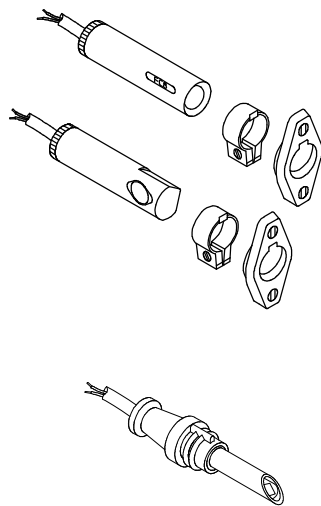

Introduction

Flame detection in fuel oil burners occurs by means of sensors detecting the presence of flame through an electrical signal, which can be used by ignition and control devices. Generally, to detect the presence of flame in these appliances a photocell is used, which exploits the light generated by the flame itself.

Description

These are the most used flame sensors for fuel oil burners. Photocells vary their ohmic resistance according to the light incidence; this property is exploited to detect the occurred flame generation in burners.

Various types of photocells are available, differing from each other for their application and casing. Fig.1 shows the FC7 and FC8 photocells; the two models differ for the position of the detecting element, which lights up laterally in the FC7 and frontally in the FC8. Fig. 2 shows the FC11 and FC13 photocells, differing from each other in the fixing system only, as they both light up laterally and frontally. Fig. 3 shows the FC14 photocell, suitable to be lit up laterally and frontally and provided with a connection plug fit to make assembling and servicing works easier. The connecting cable of photocells has a standard length of 600 mm; the operating temperature range ensuring the longest life of flame sensors (approximately 50,000 hours) is comprised between 0°C and +60°C.

Sensitivity

The sensitivity of photocells can be identified through the colour of their casing, according to the following directions:

/R	Red
/A	Blue
/V	Green

The colour red indicates photocells with standard sensitivity, the colour blue corresponds to the most sensitive photocells, whereas the colour green marks the least sensitive photocells. For the right coupling between photocell and control device please refer to our technical literature regarding control devices making use of these flame sensors. Followings are the sensitivity ranges of the available flame sensors:

Lateral side	FC7/R	1,5..5,5 lux
	FC7/A	1,5..3,0 lux
	FC7/V	3,0..5,5 lux
Frontal side	FC8/R	1,5..5,5 lux
	FC8/A	1,5..3,0 lux
	FC8/V	3,0..5,5 lux
Frontal and lateral side	FC11/R	1,5..6,5 lux
	FC11/A	1,5..3,0 lux
Frontal and lateral side	FC13/R	1,5..6,5 lux
	FC13/A	1,5..3,0 lux
Frontal and lateral side	FC14/R	1,5..6,5 lux
	FC14/A	1,5..3,0 lux

FC7-FC8 models

Drilling plane FC7 FC8

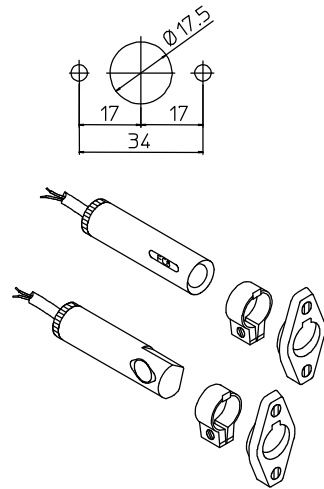

Fig. 1

FC11-FC13-FC14 models

Drilling plane FC13-FC14

Drilling plane FC11

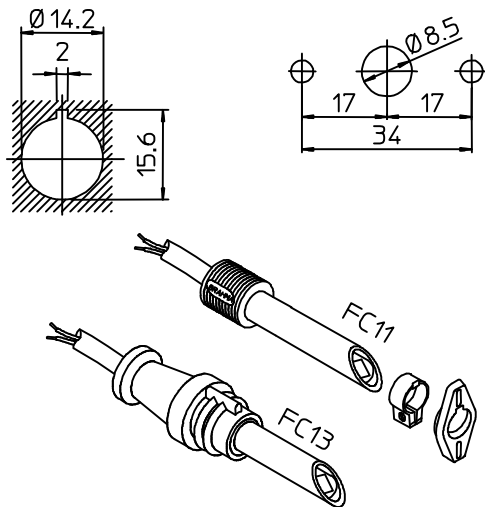

Fig. 2

To fix flame sensors type FC11, screws with diameter 4 mm are recommended.

FC14

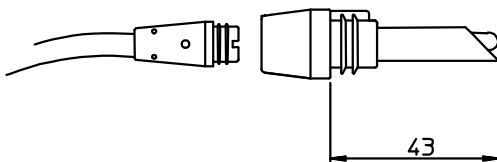

Fig. 3

ERGIO CONTROLES

La Rioja 511.
Cordoba, Argentina. CP:X5000EVK.
Tel/Fax: 0351-4250787.
<http://www.ergiocontroles.com>
E-mail: ergiocontroles@ergiocontroles.com

2003/04/10 Subject to amendments without notice